

A faded, grayscale image of a DIMM module is centered in the background. The module is a rectangular printed circuit board with various components, including a large central chip and several smaller components. The text "Voipac.com" is visible on the board.

# Voipac PXA270 DIMM Module

## Datasheet

Date	Revision	Changes
20. September 2006	1.0	Initial Release
17. April 2009	1.1	Update

## Table of Contents

1. Introduction.....	3
1.1 Hardware.....	3
1.2 Software.....	3
1.3 Features Summary.....	4
1.4 Reference Documents.....	4
2. Functional Description.....	5
2.1 Block Diagram.....	5
3. SODIMM Signal Description.....	6
3.1 IO Types Notation.....	6
3.2 Pinout Description.....	6
4. Voipac PXA270 module Connectors.....	13
4.1 Physical Locations.....	13
4.3 JTAG.....	13
4.4 Additional GPIOs (FCC1).....	14
5. Compatibility.....	15
5.1 Toradex Colibri.....	15
5.1 Keith & Koep's Trizeps III / IV.....	15
6. Technical Specifications.....	16
6.1 Electrical - DC characteristics.....	16
6.2 Mechanical.....	16
6.3 Sockets for the Voipac PXA270 module.....	18
6.4 Temperature Range.....	18
6.5 RoHS and WEEE Compliance.....	18
Warranty:.....	19
Disclaimer:.....	19
Trademark Acknowledgement:.....	19

## 1. Introduction

### 1.1 Hardware

Voipac PXA270 module is a SODIMM module based on the Intel XScale® PXA270 processor. It runs at up to 520 MHz and consumes as little as 800mW. The module delivers state of the art technology, targeting low power systems that still require high CPU performance.

Central component of the module is the PXA270 Intel XScale® processor supporting Intel® Wireless MMX™ technology. Low power requirements of the Voipac PXA270 module are achieved by using advanced power manager integrated circuit, which allows to fully control all power domains.

The Module is further equipped with SDRAM and FLASH memory chips, as well as an audio controller, 100Mbps ethernet controller full speed 12Mbps USB host and USB 2.0 OTG device functionality. Voipac PXA270 module can be supplied in a various processor and memory configurations.

Wireless Intel Speedstep® Technology, which adjusts the CPU core voltage dynamically according to the CPU load, four low-power modes, together with flexible power manager integrated circuit enable to achieve excellent MIPS/mW performance for the Voipac PXA270 module.

The entire 32 bit wide CPU bus together with available GPIO pins are available for custom extensions, such as special interfaces for high bandwidth applications.

### 1.2 Software

Since the PXA270 processor is ARM compatible various operating systems are available for the Voipac PXA270 module even by third parties. In case of unsupported operating system needed documentation for all hardware peripherals is freely available.

Voipac fully supports Linux operating system with drivers for all basic interfaces. Custom additional drivers for specific applications can be developed upon request.

Operating system	Description
Linux	Linux 2.6 with drivers for most common interfaces
Windows CE	Windows CE 6.0
QNX	

### 1.3 Features Summary

Feature	Description
CPU	PXA270@312-512MHz
SDRAM	8-256MB 32bit
FLASH	8-64MB 16bit
STORAGE	PCMCIA/CF interface 16bit, MMC/SD/SDIO interfaces
LCD	TFT/STN 18bit up to 1024x768
AUDIO/TOUCH	UCB1400 16bit up to 48kHz with resistive 4wire touch controller
VIDEO CAPTURE	CMOS/CCD image sensor interface
ETHERNET	DM9000E 10/100Mbps 32bit
USB	2xUSB Host, 1xUSB 2.0 OTG device
OTHER I/O	MSL (up to 416 Mbps), I2C, SPI, 3xRS232

### 1.4 Reference Documents

For more detailed technical information about the Voipac PXA270 module components, please refer to the web resources and documents listed below.

Component	Description
Intel Xscale® PXA270 Processor	<a href="http://voipac.com/fileDownload?fileName=Documents/pxa270dm.pdf">http://voipac.com/fileDownload?fileName=Documents/pxa270dm.pdf</a>
Davicom DM9000E Ethernet Controller	<a href="http://www.davicom.com.tw/userfile/24247/DM9000-DS-F03-041906_1.pdf">http://www.davicom.com.tw/userfile/24247/DM9000-DS-F03-041906_1.pdf</a>
Philips UCB1400 Audio Controller	<a href="http://www.nxp.com/pip/UCB1400BE.html">http://www.nxp.com/pip/UCB1400BE.html</a>
Maxim MAX1587 Power Controller	<a href="http://datasheets.maxim-ic.com/en/ds/MAX1586A-MAX1587C.pdf">http://datasheets.maxim-ic.com/en/ds/MAX1586A-MAX1587C.pdf</a>
Intel StrataFlash® Embedded Memory	<a href="http://www.mipsasoft.com/MS7/Hardware/FLASH/StrataFlash P30-T Data Sheet.pdf">http://www.mipsasoft.com/MS7/Hardware/FLASH/StrataFlash P30-T Data Sheet.pdf</a>
SAMSUNG Mobile SDR SDRAM	<a href="http://www.samsung.com/global/business/semiconductor/productList.do?fmly_id=136">http://www.samsung.com/global/business/semiconductor/productList.do?fmly_id=136</a>

## 2. Functional Description

### 2.1 Block Diagram

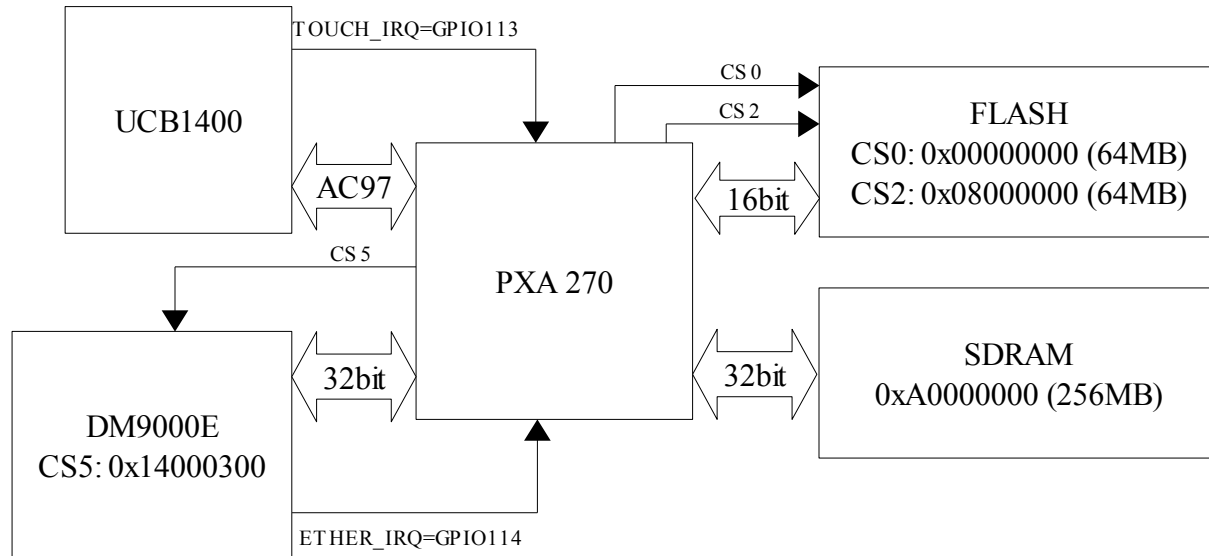

The diagram shows internal interconnection of Voipac PXA270 module. Voipac PXA270 module features full 32 bit interfaces to on board SDRAM and ethernet controller. This results in maximum bandwidth for any data transfers.

Two chip select signals are used by on board 16bit FLASH and one for the ethernet controller thus are not available on SODIMM connector. Three additional chip selects can be used by external companion chips. The diagram further shows mapping of GPIO signals used as interrupt requests from ethernet and audio controller.

Since not all PXA270 interfaces have dedicated pins some functions could not be used simultaneously.

### 3. SODIMM Signal Description

This chapter describes the signals of the Voipac PXA270 module. Some pins have dedicated functionality, but most are highly multiplexed, so that the same pin can have up to 6 different roles and the same functionality is sometimes available alternatively on different pins. Each of these multiplexed pins is additionally also usable as a General Purpose Input/Output pin (GPIO). Additionally each GPIO pin can be used as interrupt source.

#### 3.1 IO Types Notation

Signal	Description
IN	Digital CMOS input
OUT	Digital CMOS output
IO	Digital CMOS input / output
AIN	Analog input
AOUT	Analog output
AIO	Analog input / output
PWR	Power supply

#### 3.2 Pinout Description

Pin#	Pin Name	Type	Description
1	MIC_IN	AIN	Microphone Input
2	AD3	AIN	AD Converter Input 3
3	MIC_GND	PWR	Microphone Ground
4	AD2	AIN	AD Converter Input 2
5	LINEIN_L	AIN	Line Input (Left Channel)
6	AD1	AIN	AD Converter Input 1
7	LINEIN_R	AIN	Line Input (Right Channel)
8	AD0	AIN	AD Converter Input 0
9	VSSA_AUDIO	PWR	Audio Codec Ground
10	VDDA_AUDIO	PWR	Audio Codec Power supply (connect to 3.3V)
11	VSSA_AUDIO	PWR	Audio Codec Ground
12	VDDA_AUDIO	PWR	Audio Codec Power supply (connect to 3.3V)
13	HEADPHONE_GND	PWR	Headphone Ground
14	TSPX	AIO	4wire Resistive Touch Panel (X Plus Terminal)

Pin#	Pin Name	Type	Description
15	HEADPHONE_L	AOUT	Headphone Output (Left Channel)
16	TSMX	AIO	4wire Resistive Touch Panel (X Minus Terminal)
17	HEADPHONE_R	AOUT	Headphone Output (Right Channel)
18	TSPY	AIO	4wire Resistive Touch Panel (Y Plus Terminal)
19	GPIO46/STD_RXD	IN	Receive Pin for Standard UART
20	TSMY	AIO	4wire Resistive Touch Panel (Y Minus Terminal)
21	GPIO47/STD_TXD	OUT	Transmit Pin for Standard UART
22	VDD_FAULT	IN	VDD Fault: This input signals that the main power source is going out of regulation. nVDD_FAULT causes the PXA27x processor to enter sleep mode or, if PMCR[VIDAE] is set, forces an imprecise-data abort, which cannot be masked. nVDD_FAULT is ignored after a wake-up event until the power supply timer completes (approximately 10 ms).
23	GPIO40/FF_DTR	OUT	Full-Function UART Data-Terminal-Ready
24	BATT_FAULT	IN	Main Battery Fault: This input signals that the main battery is low or removed. Assertion causes the PXA27x processor to enter sleep mode or, if PMCR[BIDAE] is set, forces an imprecise-data abort, which cannot be masked. The PXA27x processor does not recognize a wake-up event while this signal is asserted.
25	GPIO100/FF_CTS	IN	Full-Function UART Clear-to-Send
26	nRESET_IN	IN	Reset: This active-low, level-sensitive input starts the processor from the reset vector at address 0. Assertion causes the current instruction to terminate abnormally and causes a reset. When nRESET is driven high, the processor starts execution from address 0. nRESET must remain low until the power supply is stable and the internal 13-MHz oscillator has stabilized.
27	GPIO27/FF_RTS	OUT	Full-Function UART Request-to-Send
28	GPIO11		
29	GPIO33/FF_DSR	IN	Full-Function UART Data-Set-Ready
30	GPIO16		
31	GPIO10/FF_DCD	IN	Full-Function UART Data-Carrier-Detect
32	GPIO44/BT_CTS	IN	Bluetooth UART Clear-to-Send
33	GPIO34/FF_RXD	IN	Full-Function UART Receive Data
34	GPIO45/BT_RTS	OUT	Bluetooth UART Request-to-Send
35	GPIO39/FF_TXD	OUT	Full-Function UART Transmit Data
36	GPIO42/BT_RXD	IN	Bluetooth UART Receive Data
37	GPIO38/FF_RI	IN	Full-Function UART Ring Indicator
38	GPIO43/BT_TXD	OUT	Bluetooth UART Transmit Data
39	GND	PWR	Ground
40	+3V3	PWR	Main power supply (connect to 3.3V)
41	GND	PWR	Ground
42	+3V3	PWR	Main power supply (connect to 3.3V)
43	GPIO0		
44	GPIO77/L_BIAS	OUT	LCD Bias Drive: AC bias that signals the LCD display module to switch the polarity of the power supplies to the row and column axis of the screen to counteract DC offset. In active (TFT) mode, it is used as the output enable to signal when data should be latched from the data pins using the pixel clock.
45	GPIO1		
46	GPIO65/LDD07	IO	LCD Display Data 7

Pin#	Pin Name	Type	Description
47	GPIO32/MMCLK	OUT	MMC and SD/SDIO Card Bus Clock
48	GPIO67/LDD09	IO	LCD Display Data 9
49	GPIO109/MMDAT1	IO	MMC and SD/SDIO Data 1
50	GPIO69/LDD11	IO	LCD Display Data 11
51	GPIO110/MMDAT2/MMCS0	IO	SD/SDIO Data 2 or MMC Chip Select 0
52	GPIO70/LDD12	IO	LCD Display Data 12
53	GPIO111/MMDAT3/MMCS1	IO	SD/SDIO Data 3 or MMC Chip Select 1
54	GPIO71/LDD13	IO	LCD Display Data 13
55	GPIO19/L_CS	OUT	LCD Chip Select: Chip select signal for LCD panels with an internal frame buffer.
56	GPIO76/L_PCLK_WR	OUT	LCD Pixel Clock: Pixel clock used by the LCD display module to clock the pixel data into the line shift register. In passive mode, the pixel clock toggles only when valid data is available on the data pins. In active mode, the pixel clock toggles continuously, and the AC bias pin is used as an output to signal when data is valid on the LCD data pins. This pin also functions as a write signal for LCD panels with an internal frame buffer.
57	GPIO86/LDD16	IO	LCD Display Data 16
58	GPIO61/LDD03	IO	LCD Display Data 3
59	GPIO12		
60	GPIO60/LDD02	IO	LCD Display Data 2
61	GPIO87/LDD17	IO	LCD Display Data 17
62	GPIO66/LDD08	IO	LCD Display Data 8
63	GPIO14		
64	GPIO73/LDD15	IO	LCD Display Data 15
65	GPIO106		
66	GPIO72/LDD14	IO	LCD Display Data 14
67	GPIO17		
68	GPIO75/L_LCLK_A0	OUT	LCD Line Clock: Indicates the start of a new line. Also referred to as HSync (or horizontal synchronization) for active panels. For LCDs with an internal frame buffer, this signal indicates a command or data transaction.
69	GPIO20		
70	GPIO59/LDD01	IO	LCD Display Data 1
71	GPIO81		
72	GPIO63/LDD05	IO	LCD Display Data 5
73	GPIO52		
74	GPIO68/LDD10	IO	LCD Display Data 10
75	GPIO53		
76	GPIO58/LDD00	IO	LCD Display Data 0
77	GPIO82		
78	GPIO62/LDD04	IO	LCD Display Data 4
79	GPIO83		
80	GPIO64/LDD06	IO	LCD Display Data 6
81	GPIO84		
82	GPIO74/L_FCLK_RD	OUT	LCD Frame Clock: Frame clock used by the LCD display module to signal the start of a new frame of pixels that resets the line pointers to the top of the screen. This pin is also

Pin#	Pin Name	Type	Description
			the vertical synchronization signal for active (TFT) displays. This pin is the read signal during reads from a panel with an internal frame buffers.
83	GND	PWR	Ground
84	+3V3	PWR	Main power supply (connect to 3.3V)
85	GPIO107		
86	GPIO24/SSPFRM	IO	Synchronous Serial Port 1 Frame: The serial frame sync can be configured as an output (master-mode) or an input (slave-mode).
87	nRESET_OUT	OUT	Reset Out: Asserted when nRESET is asserted, it deasserts after nRESET is deasserted but before the first instruction fetch occurs. nRESET_OUT is asserted during power-on, hardware, watchdog, and sleep-exit resets. It is configurable for GPIO reset.
88	GPIO23/SSPCLK	IO	Synchronous Serial Port 1 Clock: The serial bit-clock can be configured as an output (master-mode) or an input (slave-mode).
89	nWE	O	Memory Write Enable: Connect to the write enables of SDRAM and static memory devices.
90	GPIO26/SSPRXD	IN	Synchronous Serial Port 1 Receive Data: Serial data latched using the bit-clock.
91	nOE	O	Memory Output Enable: Connect to the output enables of static memory devices to control data bus drivers.
92	GPIO25/SSPTXD	OUT	Synchronous Serial Port 1 Transmit Data: Serial data driven out synchronously with the bit-clock.
93	RDnWR	OUT	Read/Write: Indicates that the current transaction is a read (high) or a write (low)
94	GPIO85/nPCE1	OUT	PC Card Enable 1: Selects a PC Card. nPCE1 enables the low byte lane.
95	RDY(GPIO18)	IN	Variable Latency I/O Ready Pin: An external variable-latency I/O (VLIO) device asserts RDY when it is ready to transfer data.
96	GPIO54/nPCE2	OUT	PC Card Enable 2: Selects a PC Card. nPCE2 enables the high byte lane.
97	GPIO48/nPOE	OUT	PC Card Output Enable: Output enable for reads from PC Card memory and PC Card attribute space.
98	GPIO55/nPREG	OUT	PC Card Register Select: Functions as address bit 26 to select register space (I/O or attribute) or memory space. Has the same timing as the address bus.
99	nPWE(GPIO49)	OUT	PC Card Write Enable: Enables writes to PC Card memory and PC Card attribute space. Also serves as the write enable signal for variable-latency I/O.
100	GPIO104/PSKTSEL	OUT	PC Card Socket Select: Used by external steering logic to route control, address, and data signals to one of the two PC Card sockets. Active-low output enable that can be used as nOE for the data transceivers. The signal has the same timing as the address bus. In a single socket solution: 0 = Output enable selected 1 = Output enable not selected In a dual socket solution, the socket select: 0 = Socket 0 selected 1 = Socket 1 selected
101	GPIO51/nPIOW	OUT	PC Card I/O Write: Asserted for writes to PC Card I/O space.
102	GPIO56/nPWAIT	IN	PC Card Wait: Driven low by the PC Card to insert wait states, which extend transfers to and from the PXA27x processor.
103	GPIO50/nPIOR	OUT	PC Card I/O Read: Asserted for reads from PC Card I/O space.
104	GPIO57/nIOIS16	IN	I/O Select 16: Input from the PC Card indicating that the data bus: 0 = Data bus is 8 bits wide 1 = Data bus is 16 bits wide
105	GPIO15/nCS1	OUT	Static Chip Select 1: Physical Address 0x04000000 Static Chip Selects: Chip selects to static memory devices such as ROM and flash, individually programmable in the memory configuration registers.

Pin#	Pin Name	Type	Description
			nCS<5:0> can be used with variable-latency I/O devices. nCS<3:0> can be used with synchronous flash.
106	GPIO80/nCS4	OUT	Static Chip Select 4: Physical Address 0x10000000
107	GPIO79/nCS3	OUT	Static Chip Select 3: Physical Address 0x0C000000
108	+3V3	PWR	Main power supply (connect to 3.3V)
109	GND	PWR	Ground
110	MA08	OUT	MA[25:0] Memory Address Bus: Address for external memory accesses.
111	MA00	OUT	
112	MA09	OUT	
113	MA01	OUT	
114	MA10	OUT	
115	MA02	OUT	
116	MA11	OUT	
117	MA03	OUT	
118	MA12	OUT	
119	MA04	OUT	
120	MA13	OUT	
121	MA05	OUT	
122	MA14	OUT	
123	MA06	OUT	
124	MA15	OUT	
125	MA07	OUT	
126	DQM0	OUT	DQM Data Byte Mask Control 0: Corresponds to MD<7:0>.
127	GPIO36/OTG_VBUS_EN		
128	DQM1	OUT	DQM Data Byte Mask Control 1: Corresponds to MD<15:8>.
129	GPIO89/USBH1_PEN	OUT	USB Host Power Enable: Controls power IC for USB host port.
130	DQM2	OUT	DQM Data Byte Mask Control 2: Corresponds to MD<23:16>.
131	GPIO88/USBH1_OC	IN	USB Host Power Indicator: Over-current indicator from USB power IC for USB host port.
132	DQM3	OUT	DQM Data Byte Mask Control 3: Corresponds to MD<31:24>.
133	GPIO37/OTG_VBUS_PULSE		
134	MA25	OUT	
135	GPIO35/OTG_SRP_DETECT		
136	MA24	OUT	
137	GPIO41/OTG_ID		
138	MA23	OUT	
139	USBH_P	IO	USB Host Positive Line: Differential signal connects to the USB host interface.
140	MA22	OUT	
141	USBH_N	IO	USB Host Negative Line: Differential signal connects to the USB host interface.
142	MA21	OUT	
143	USBC_P	IO	USB Client Positive Line: Differential signal connects to the USB client interface.
144	MA20	OUT	

# Voipac PXA270 DIMM Module Datasheet



Pin#	Pin Name	Type	Description
145	USBC_N	IO	USB Client Negative Line: Differential signal connects to the USB client interface.
146	MA19	OUT	
147	GND	PWR	Ground
148	+3V3	PWR	Main power supply (connect to 3.3V)
149	MD00	IO	MD[32:0] Memory Data Bus: Data bus to and from external memory devices.
150	MD16	IO	
151	MD01	IO	
152	MD17	IO	
153	MD02	IO	
154	MD18	IO	
155	MD03	IO	
156	MD19	IO	
157	MD04	IO	
158	MD20	IO	
159	MD05	IO	
160	MD21	IO	
161	MD06	IO	
162	MD22	IO	
163	MD07	IO	
164	MD23	IO	
165	MD08	IO	
166	MD24	IO	
167	MD09	IO	
168	MD25	IO	
169	MD10	IO	
170	MD26	IO	
171	MD11	IO	
172	MD27	IO	
173	MD12	IO	
174	MD28	IO	
175	MD13	IO	
176	MD29	IO	
177	MD14	IO	
178	MD30	IO	
179	MD15	IO	
180	MD31	IO	
181	GND	PWR	Ground
182	+3V3	PWR	Main power supply (connect to 3.3V)
183	nETH_LINK_ACT	OUT	Ethernet Activity Indicator
184	MA18	OUT	

## Voipac PXA270 DIMM Module Datasheet



Pin#	Pin Name	Type	Description
185	nETH_SPEED100	OUT	Ethernet Speed Indicator
186	MA17	OUT	
187	ETH_TXO-	OUT	Ethernet TX Differential Output (minus)
188	MA16	OUT	
189	ETH_TXO+	OUT	Ethernet TX Differential Output (plus)
190	GPIO112/MMCMD	IO	MMC and SD/SDIO command and response tokens.
191	ETH_AGND	PWR	Ethernet Analog Ground
192	GPIO92/MMDAT0	IO	MMC and SD/SDIO Data 0
193	ETH_RXI-	IN	Ethernet RX Differential Input (minus)
194	GPIO118/I2C_DATA	IO	I2C Data: Serial data/address bus.
195	ETH_RXI+	IN	Ethernet RX Differential Input (plus)
196	GPIO117/I2C_CLK	IO	I2C Clock: Serial clock.
197	GND	PWR	Ground
198	+3V3	PWR	Main power supply (connect to 3.3V)
199	GND	PWR	Ground
200	+3V3	PWR	Main power supply (connect to 3.3V)

## 4. Voipac PXA270 module Connectors

### 4.1 Physical Locations

Along with the main 200pin SODIMM connector the Voipac PXA270 module is equipped with one additional FCC connector (standardly not mounted) and pads for board-to-board pitch compression connector. The positions are shown in the figure below.

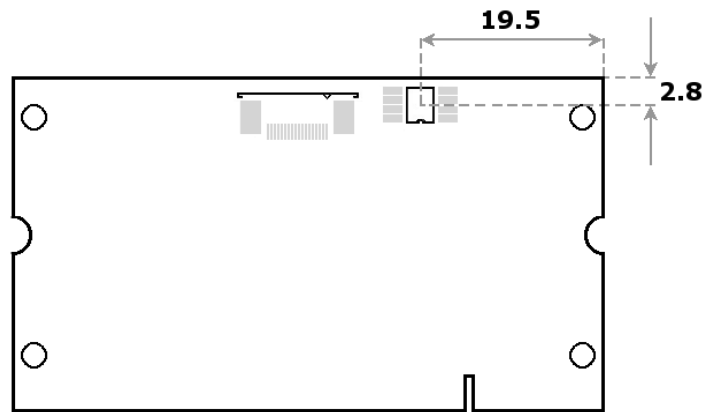

Dimensions are given in mm

### 4.3 JTAG

Connector: Molex 47041-0001 [www.molex.com](http://www.molex.com)

Pin#	Pin Name	Type	Description
1	+3V3	PWR	Supply power to power up JTAG logic
2	GND	PWR	Ground
3	TMS	IN	JTAG mode select
4	nTRST	IN	JTAG reset
5	TCK	IN	JTAG clock
6	TDO	OUT	JTAG Data output
7	TDI	IN	JTAG Data input
8	nSRST	OUT	System reset

#### 4.4 Additional GPIOs (FCC1)

Connector: FCC 18 pins, 0.5mm pitch, bottom contact

Pin#	Pin Name	Type	Description
1	GPIO9	IO	
2	GPIO13	IO	
3	GPIO21	IO	
4	GPIO22	IO	
5	GPIO90	IO	
6	GPIO91	IO	
7	GPIO93	IO	
8	GPIO94	IO	
9	GPIO96	IO	
10	GPIO97	IO	
11	GPIO99	IO	
12	GPIO101	IO	
13	GPIO102	IO	
14	GPIO103	IO	
15	GPIO105	IO	
16	GPIO108	IO	
17	GPIO115	IO	
18	GPIO116	IO	

## **5. Compatibility**

Voipac PXA270 modules can be used as a replacement for Toradex Colibri modules and after adjustments to GPIO pin mapping also for Keith & Koep's Trizeps III / IV family of modules. This chapter points out the differences for a smooth transition.

### **5.1 Toradex Colibri**

Voipac PXA270 module and Colibri share exactly the same pin mapping regarding all SODIMM pins. However, since Voipac PXA270 module implements four SDRAM banks some memory configurations will require two additional GPIO pins to be used as SDRAM chip selects and thus not available for customer designs.

The second FLASH bank also uses CS2 which is used by ethernet controller on Colibri module. By an assembly option it is possible to assign CS2 for ethernet controller too, while second FLASH bank is not being used. Additionally the ethernet controller has offset of 0x300 relative to used chip select physical base address.

### **5.1 Keith & Koep's Trizeps III / IV**

Voipac PXA270 module and Trizeps share a compatible pin mapping regarding all pins as GPIOs. However, the mapping GPIO to SODIMM pin is not identical. As long as Voipac PXA270 module pins are used only as GPIOs, the modules are hardware compatible.

Slight software adoptions are necessary in most projects to transition between Voipac PXA270 module and Trizeps III / IV to remap the GPIO pins.



Top Layer

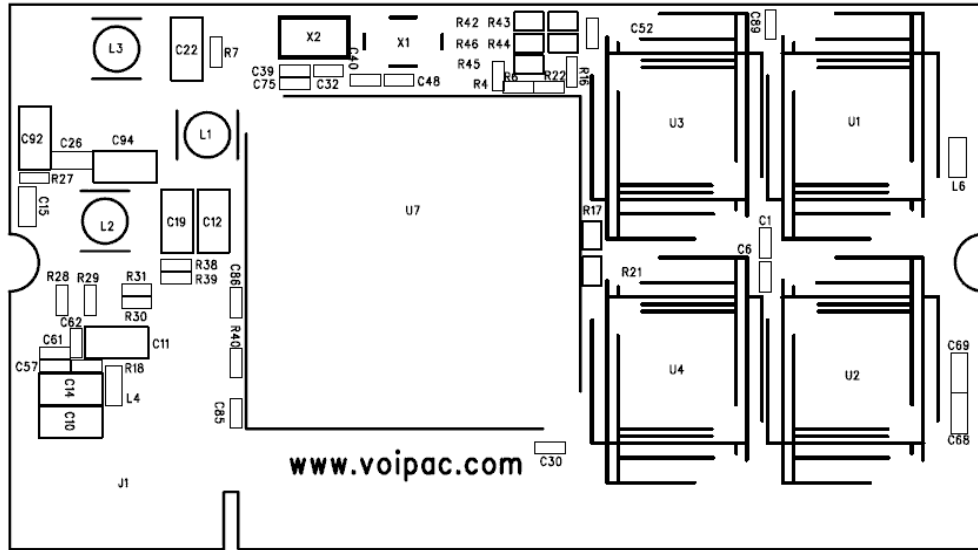

Bottom Layer

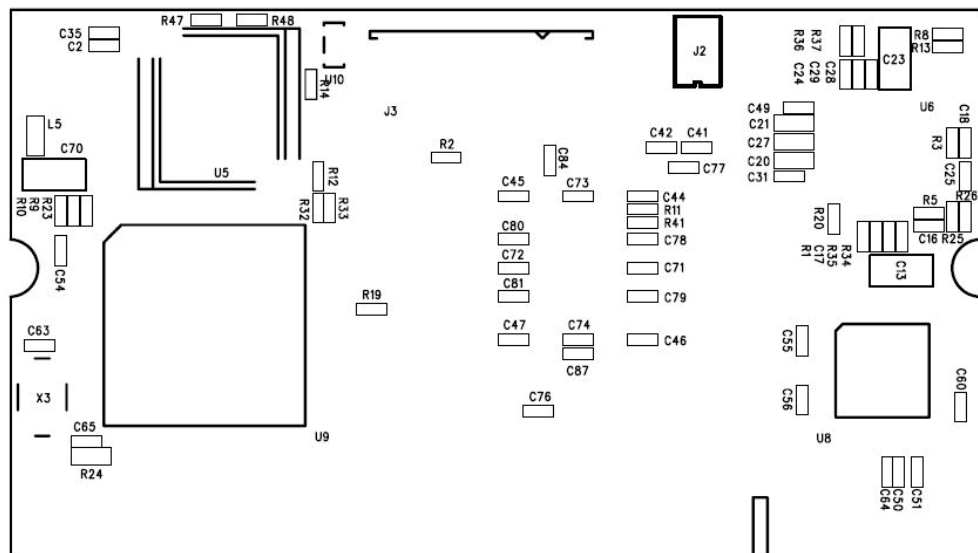

### 6.3 Sockets for the Voipac PXA270 module

The Voipac PXA270 module fits into a regular 2.5V DDR1 SODIMM memory socket

### 6.4 Temperature Range

Symbol	Description	Min	Type	Max	Unit
T_AMB	Operating temperature range	0		70	°C
T_AMB	Operating temperature range without ethernet	-25		85	°C

### 6.5 RoHS and WEEE Compliance

All of the products designed and manufactured by Voipac Technologies are classified as Electrical and Electronic Equipment (EEE) under the Directive on the restriction of the use of certain hazardous substances in electrical and electronic equipment 2002/95/EC (RoHS). To comply with the RoHS directive, the restricted use of Lead (Pb), Mercury (Hg), Cadmium (Cd), Hexavalent Chromium (Cr 6+), Polybrominated Biphenyls (PBB) and Polybrominated Diphenyl Ethers (PBDE) must be ensured. Voipac Technologies guarantees that products ordered after July 1, 2006 are assembled in full compliance with the RoHS directive from the European Parliament and Counsel. The company procedures also complies with the Waste Electrical and Electronic Equipment Directive 2002/96/EC (WEEE) .

## **Warranty:**

### **Voipac Technologies a.s. Does Not Bear Responsibility for the Following:**

- Failure of a product resulting from misuse, accident, modification, unsuitable operating environment, or improper maintenance by user
- Unless otherwise agreed in written, a product does not include technical support and the customer may be able to purchase technical support under separate agreement
- Any technical or other support provided under warranty by Voipac Technologies a.s. such as assistance, set-up and installation is provided WITHOUT WARRANTY OF ANY KIND.

## **Disclaimer:**

Voipac Technologies a.s. reserves the right to make changes, without notice, to any product, including circuits and/or software described or contained in this datasheet. Voipac Technologies a.s. assumes no responsibility or liability for the use of the described product(s), conveys no license or title under any patent, copyright, or mask work rights to these products, and makes no representations or warranties that these products are free from patent, copyright, or mask work right infringement, unless otherwise specified.

## **Trademark Acknowledgement:**

Brand and product names are trademarks or registered trademarks of their respective owners.